

CLASSIC #10

SLIDING SYSTEM - ASSEMBLY INSTRUCTIONS

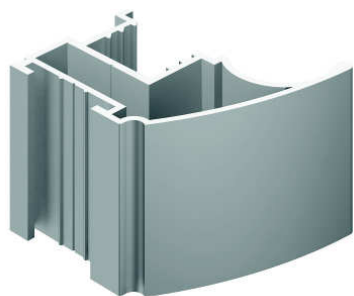

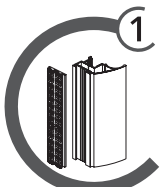
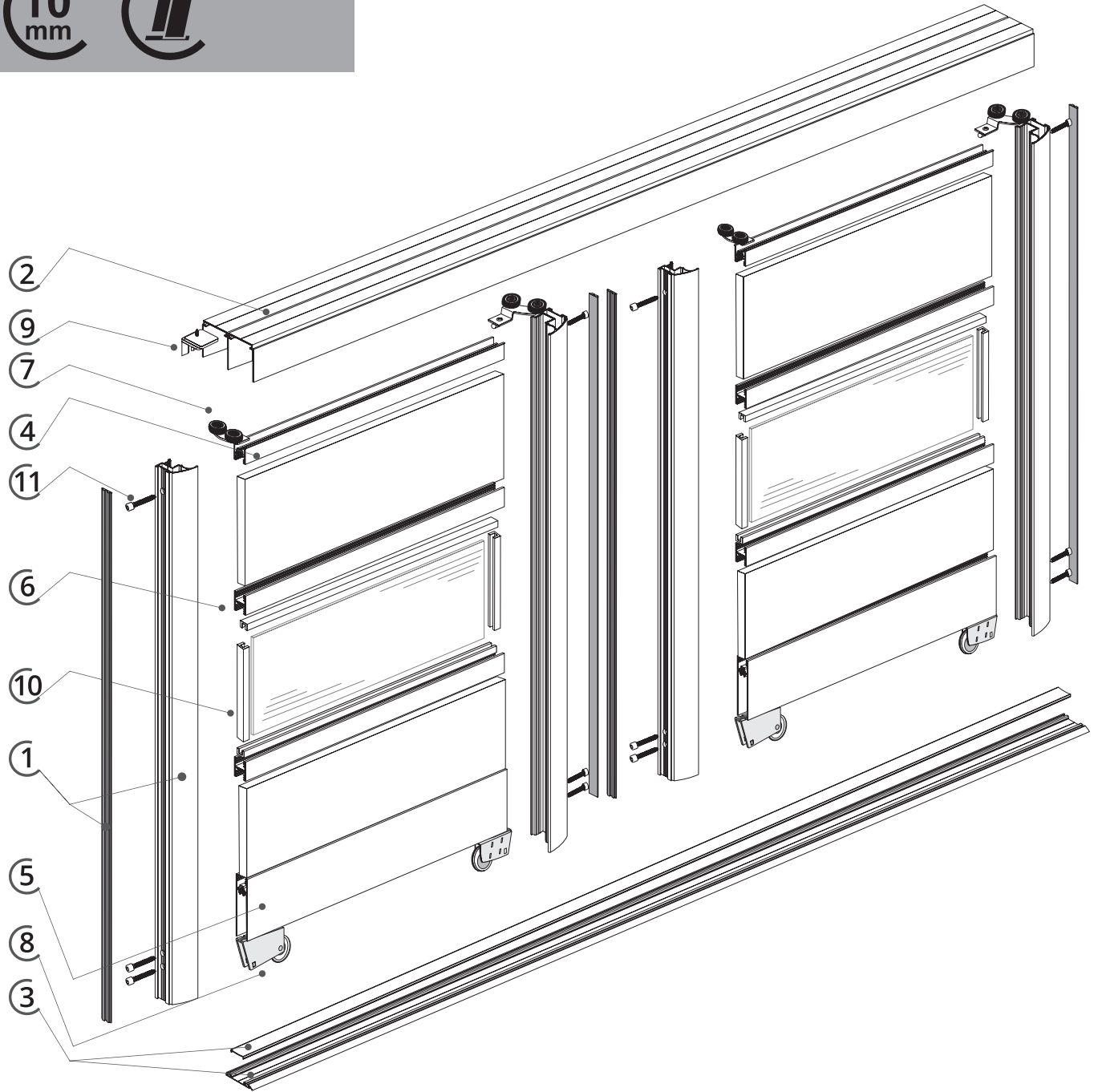

CLASSIC vertical profile
14 x 4,0 mm brush

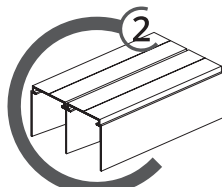

Top double rail

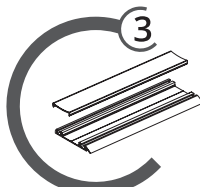

Bottom double rail
Bottom rail cover

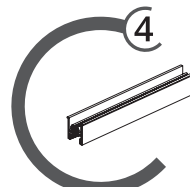

#10 Top horizontal
profile

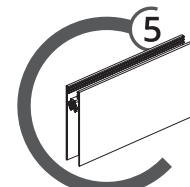

#10 Bottom horizontal
profile

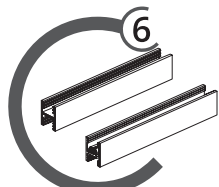

#10 H profile
#10 H+ profile

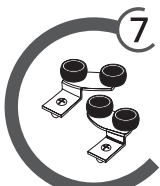

#10 top asymmetrical
wheel L / R

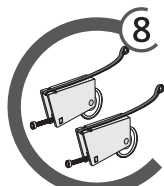

#10 bottom wheel



Top stopper

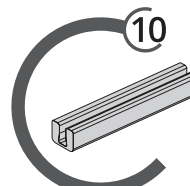

Seal for glass

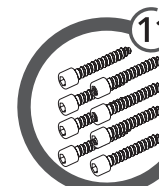

6x32mm
sheet metal screw

Calculations:

- DOOR LEAF HEIGHT = INTERIOR HEIGHT - 40 mm
- DOOR LEAF HEIGHT = VERTICAL PROFILE'S LENGTH
- BOARD HEIGHT = DOOR LEAF HEIGHT - 64,9 mm
- OVERLAP POINT = (NUMBER OF DOOR LEAF - 1) x 30 mm
- DOOR LEAF WIDTH = INTERIOR WIDTH + OVERLAP POINT / NUMBER OF DOORS
- BOARD WIDTH = DOOR LEAF WIDTH - 19,4 mm
- HORIZONTAL PROFILES LENGTH (L, H, H+, T) = DOOR LEAF WIDTH - 36,8 mm

overlap points [Z] for different door leaf number

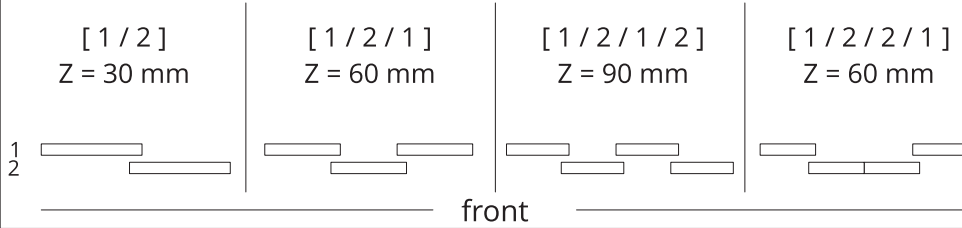

CLASSIC

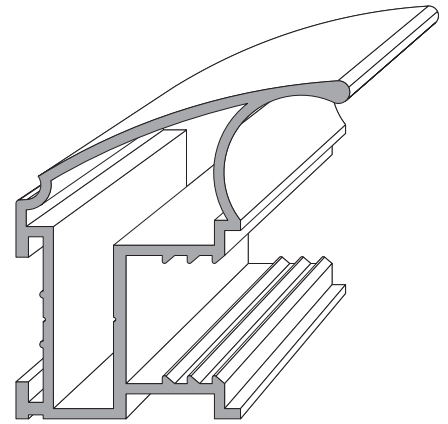

board dimension calculation

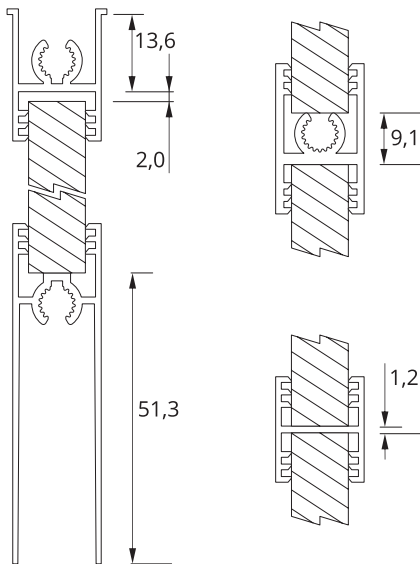

glass dimension calculation

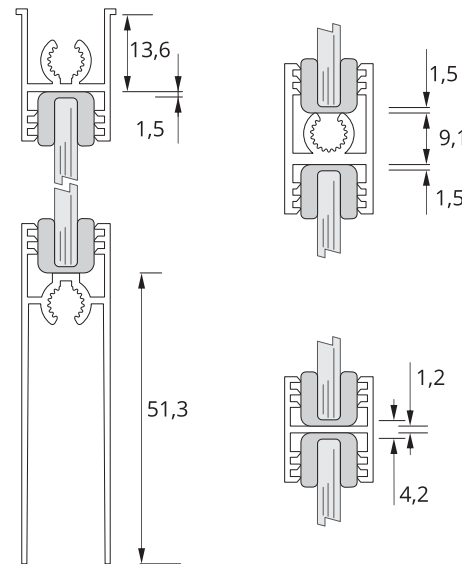

dimension calculation

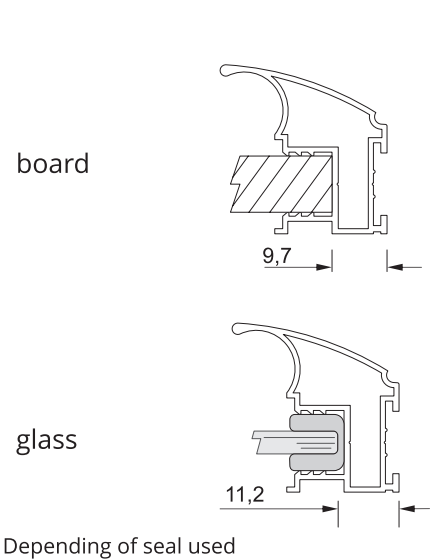

preparing vertical profiles for assembling

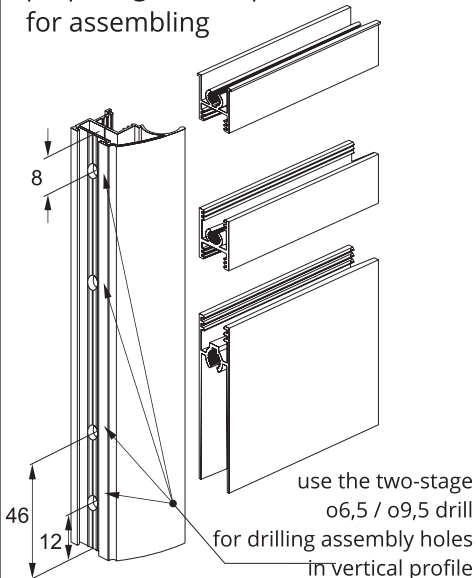

template for drilling holes in vertical profiles

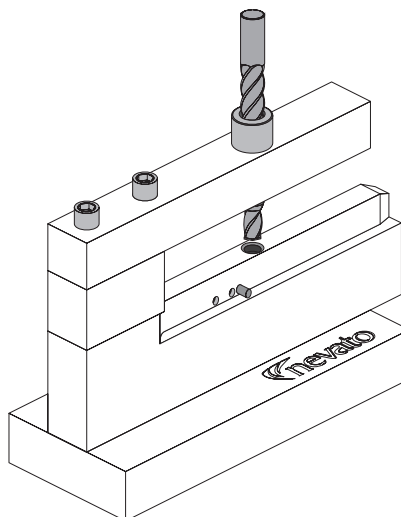

UNI template for drilling holes in vertical profiles (handy)

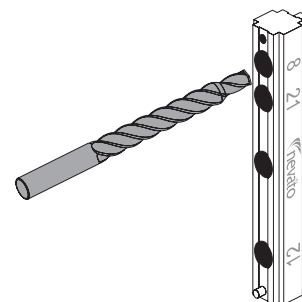

top wheel assembly

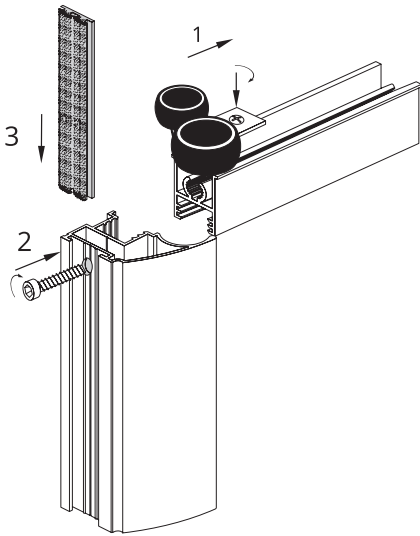

top wheel adjustment

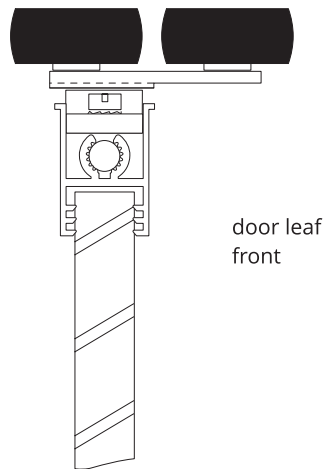

bottom wheel assembly

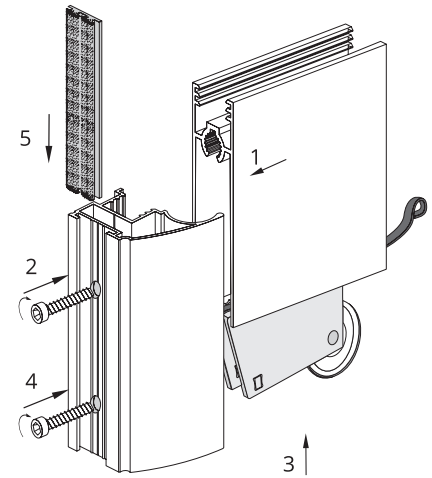

top stopper assembly

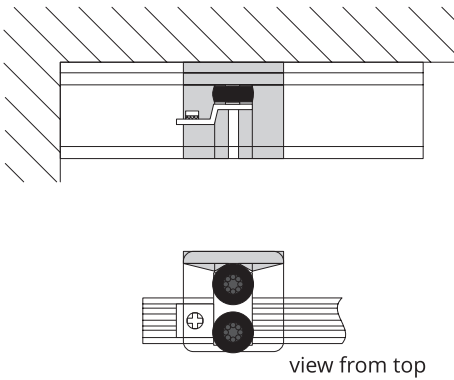

put the stopper into the rail before assembling

stopper position in the bottom rail

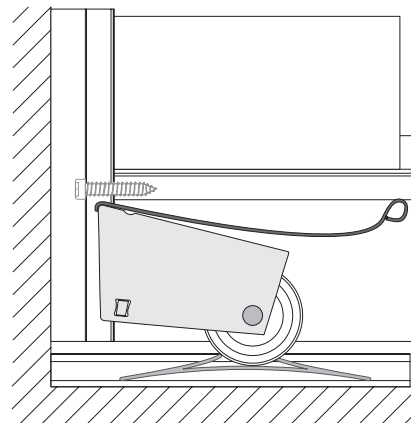

put the stopper into the rail before assembling

door assembly

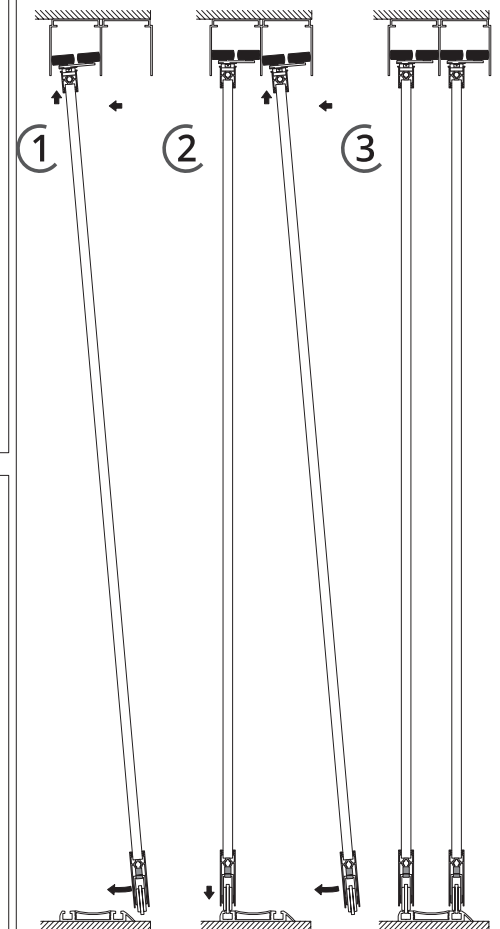

top stopper adjustment in top rail

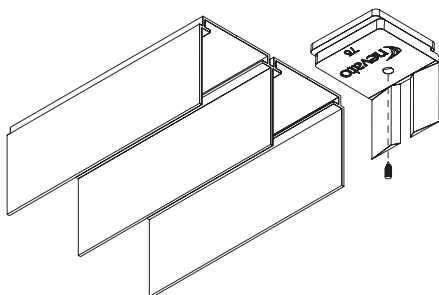

(view from bottom of the top rail)

glass assembly with seal for glass

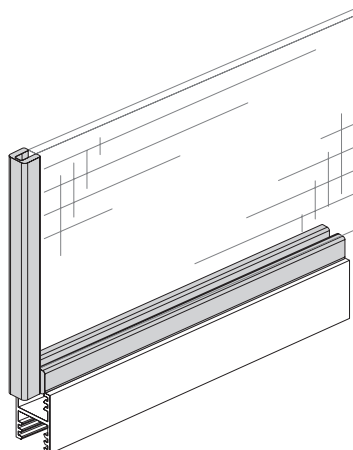

NOTE!
You should use safe glass or glass with protective foil

1-track rails assembly

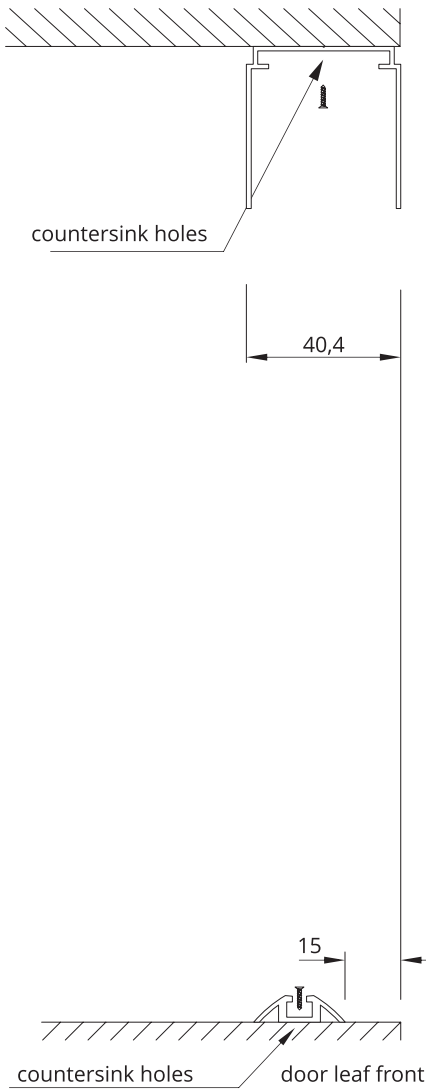

2-track rails assembly

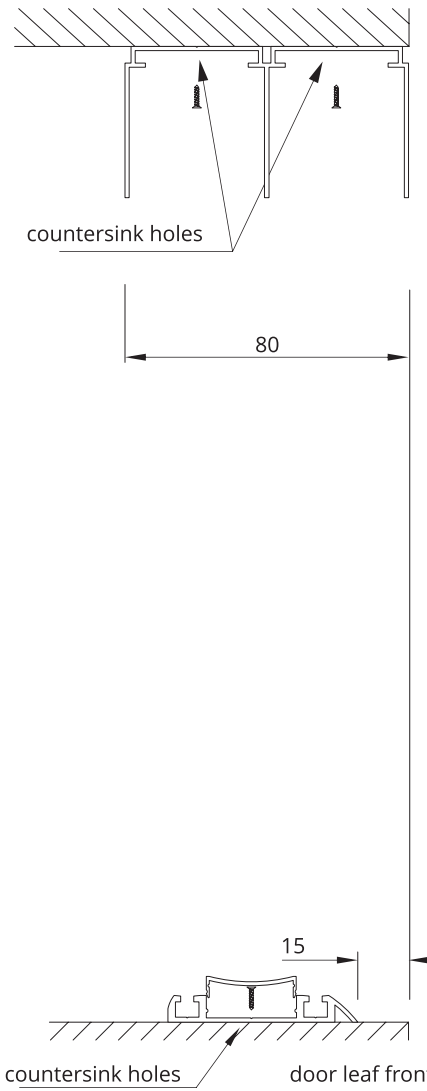

3-track rails assembly

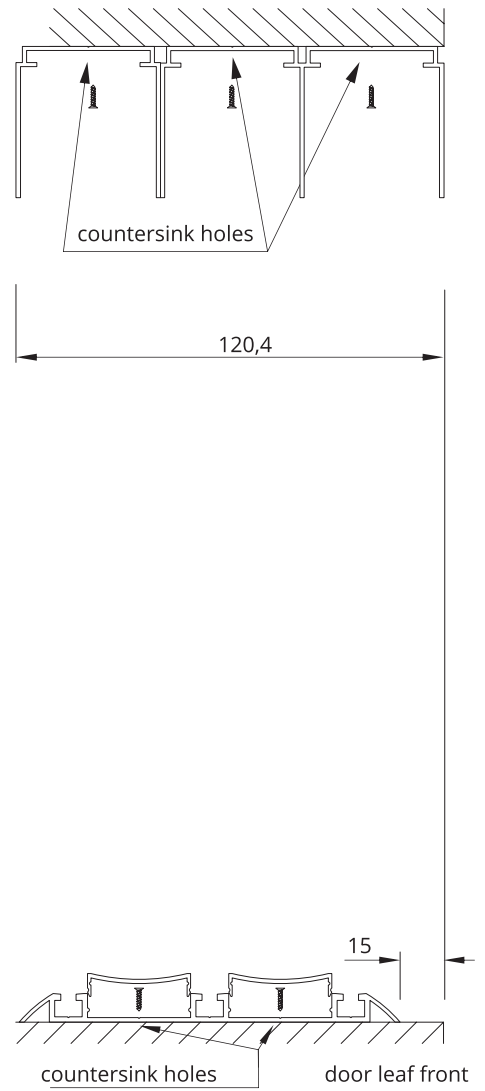

3-tracks rails options

option I

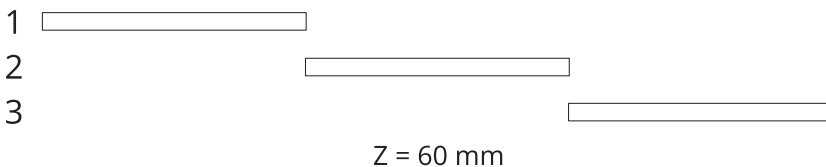

option II

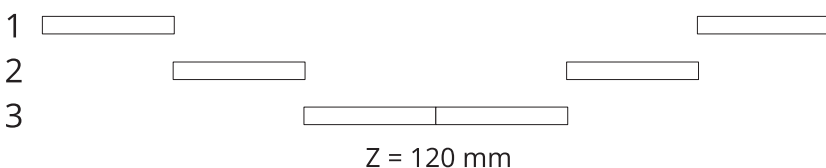

NOTE!

One door leaf maximum weight is 50 kg.

Do not use glue while fixing the profiles on the board.

Door system producer will not be responsible for door deformations caused by the use of the bad quality board.

We recommend to use connectors in order to eliminate the board tension.

You should use safe glass or glass with protective foil

CLASSIC - ANGLED SYSTEM



www.czechpol.cz

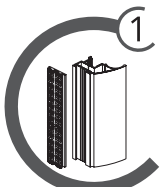
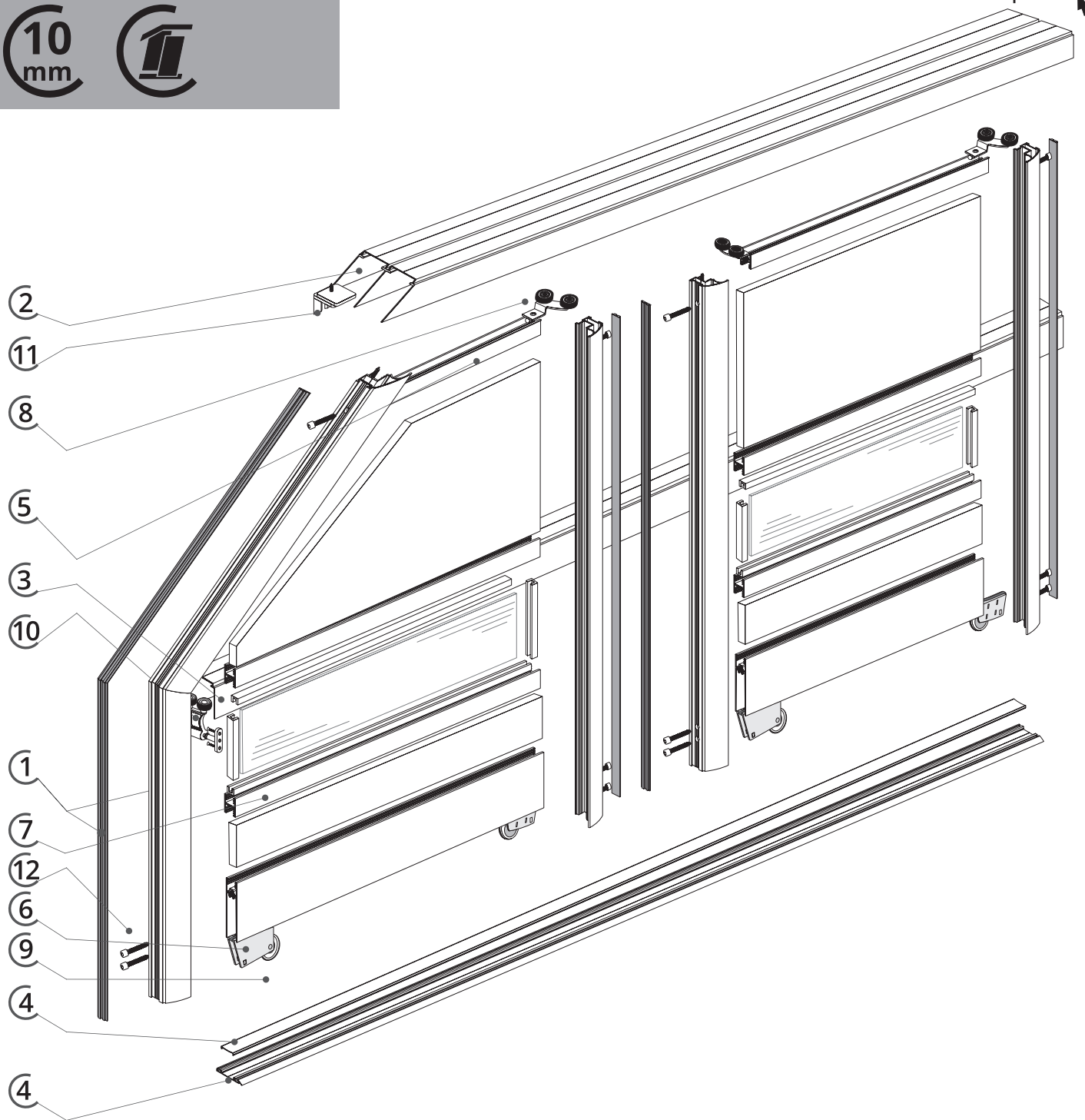

CLASSIC vertical profile
14 x 4,0 mm brush

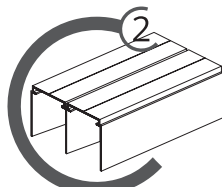

Top 2-track rail

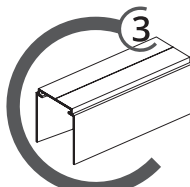

Top 1-track rail
Intermediate rail

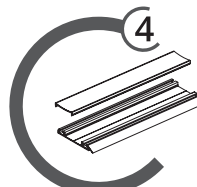

Bottom double rail
Bottom rail cover

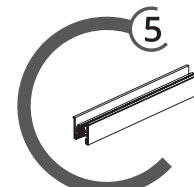

#10 Top horizontal
profile

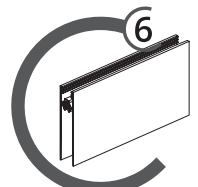

#10 Bottom horizontal
profile

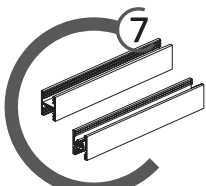

#10 H profile
#10 H+ profile

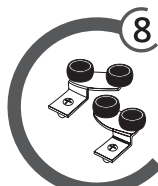

#10 top asymmetrical
wheel L / R

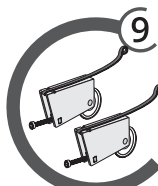

#10 bottom wheel

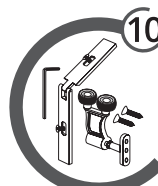

Angled doors set

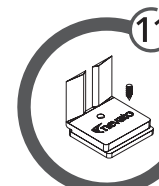

Top stopper

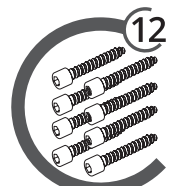

6x32mm
sheet metal screw

#10 CLASSIC

assembly dimensions

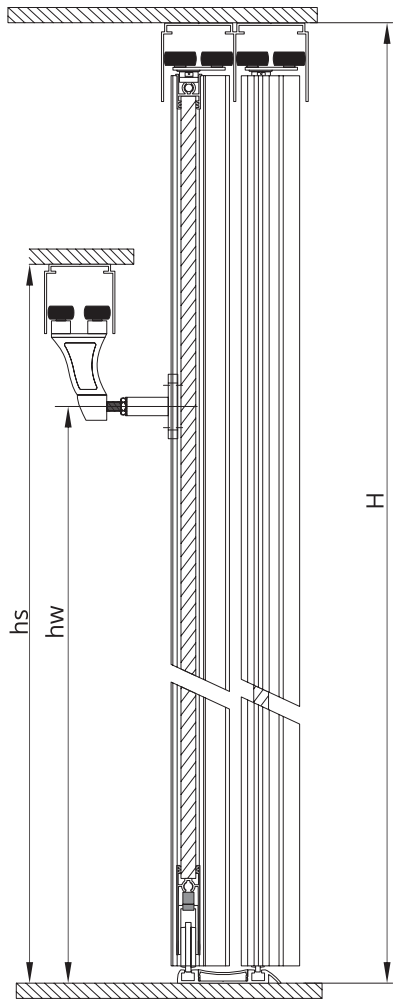

$hw = hs - 70$

assembly of doors in a niche

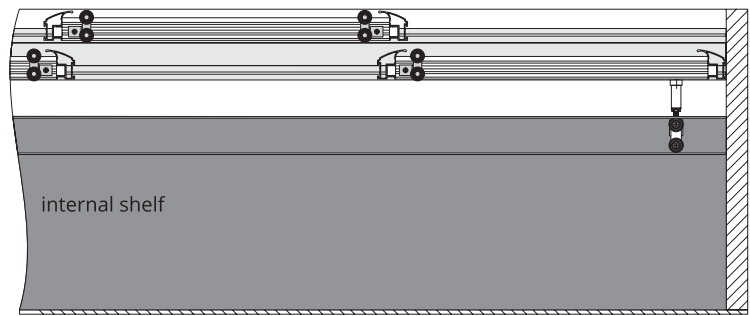

leading wheel parameters

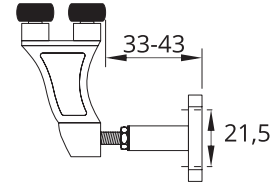

angled door installation

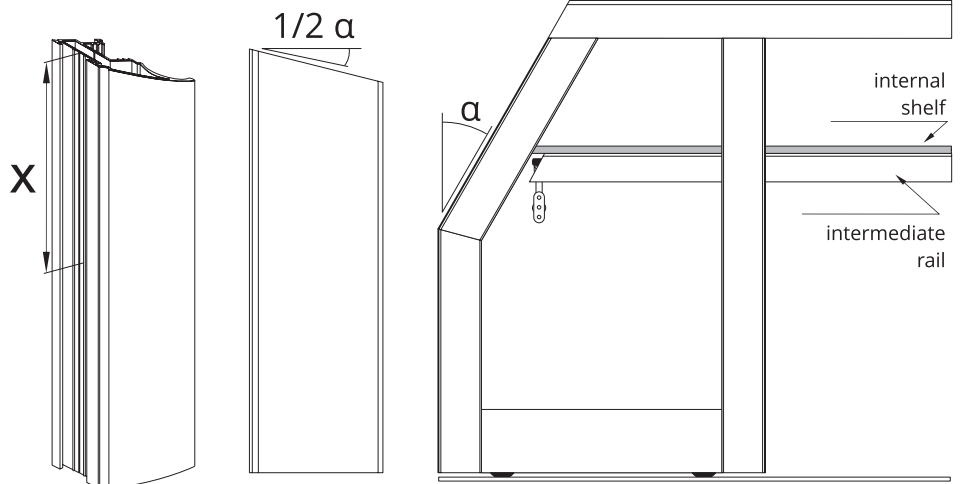

intermediate wheel assembly

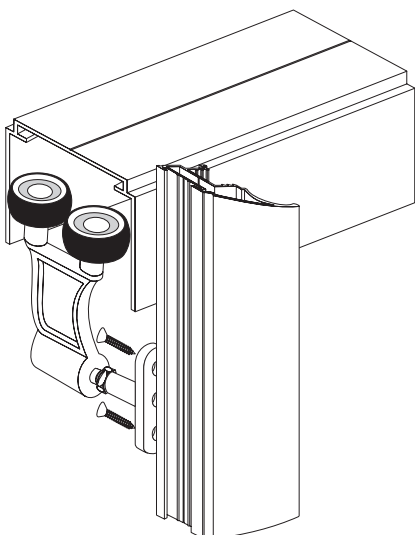

angled doors set assembly

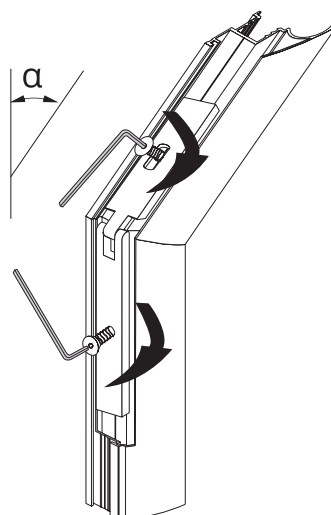

handle hinge fixing

Handle angle (α)	Drilling location of the hinge screw holes from the inner edge of the handle (x)
25	42,6
30	42,8
35	43,0
40°	43,2
45°	43,5
50°	43,7
55	43,9
60	44,2
65	44,5

SOFT CLOSE - assembly

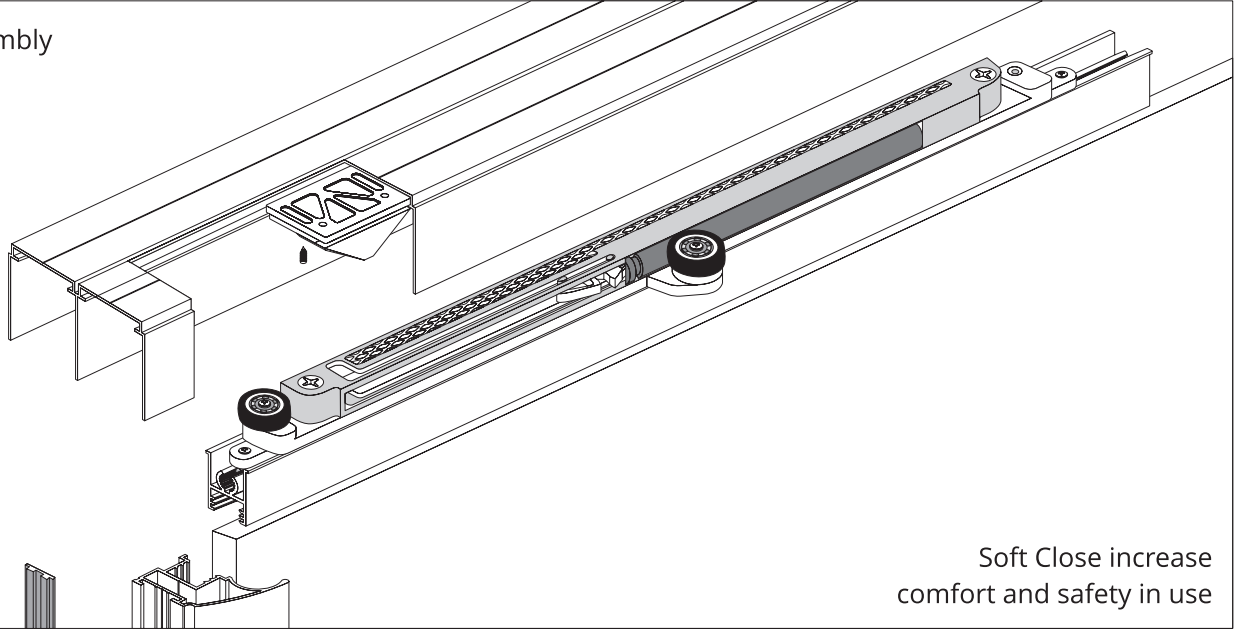

Soft Close increase comfort and safety in use

assembly of the soft closer in the door frame

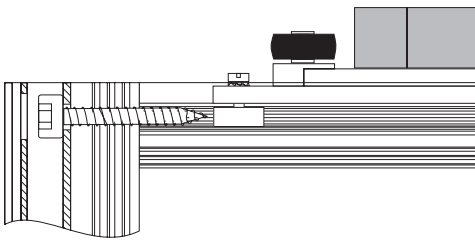

mounting the activator in top rail

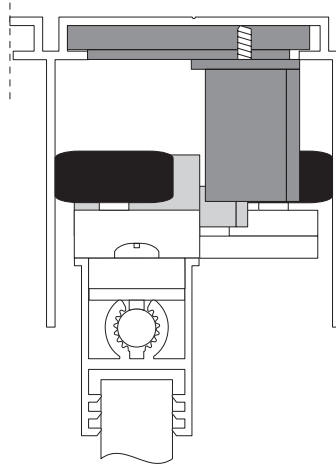

the activator should be inserted into the top rail before installing the door.

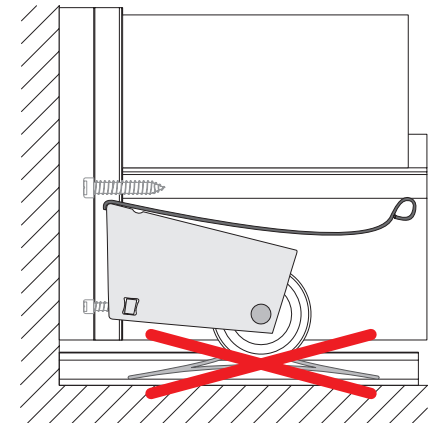

a bottom stopper is not required when using the soft closing system

location of the soft closing activator in the top rail

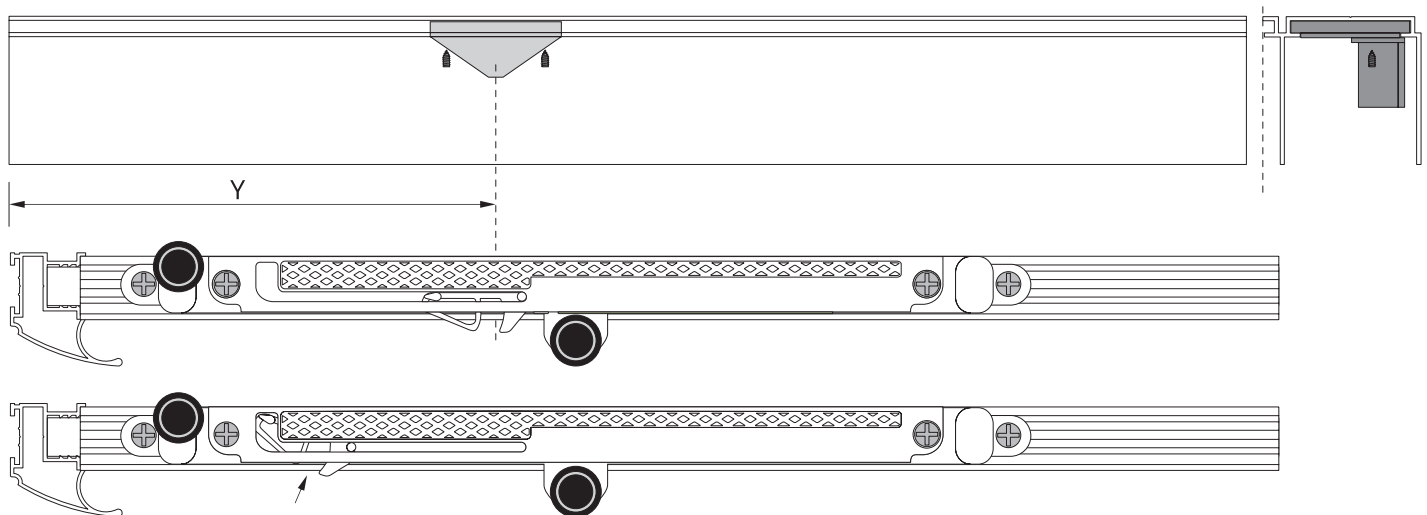

WARNING! The Soft Closer is installed with the spring extended.

3S SOFT CLOSE - assembly

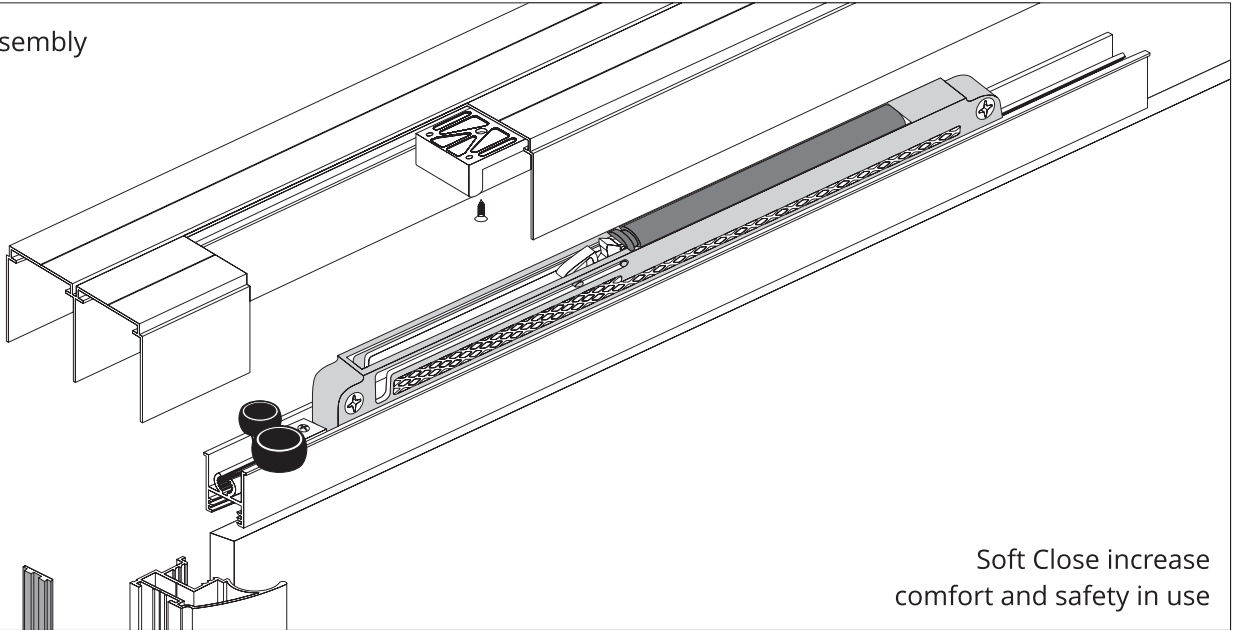

Soft Close increase comfort and safety in use

assembly of the 3S soft closer in the door frame

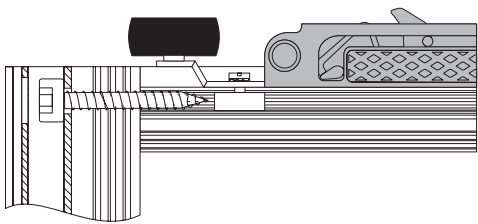

mounting the activator in top rail

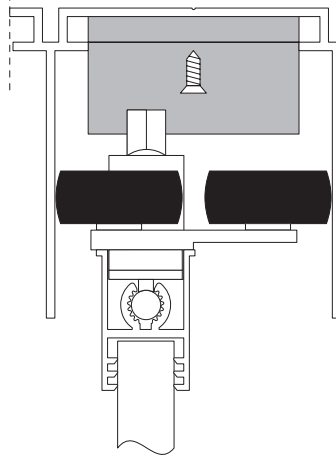

activator selection

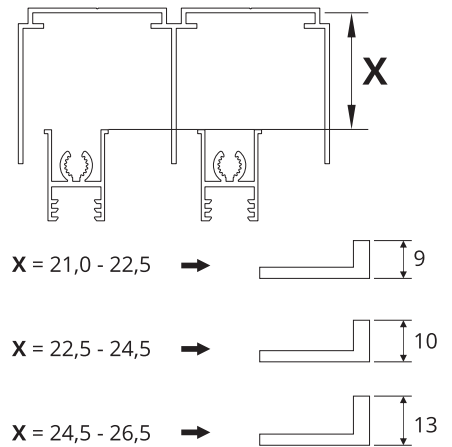

After installing and adjusting the door measure dimension X (inside the rail). Select the activator based on the measure.

location of the 3S soft closing activator in the top rail

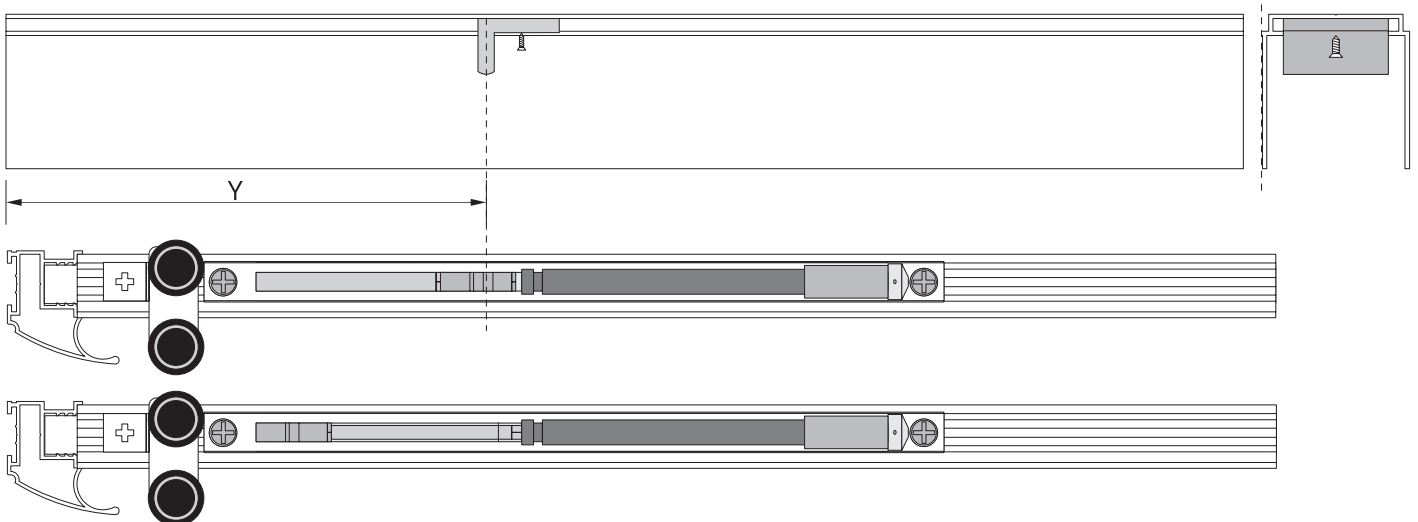

WARNING! The Soft Closer is installed with the spring extended.

MIDDLE SOFT CLOSER - assembly

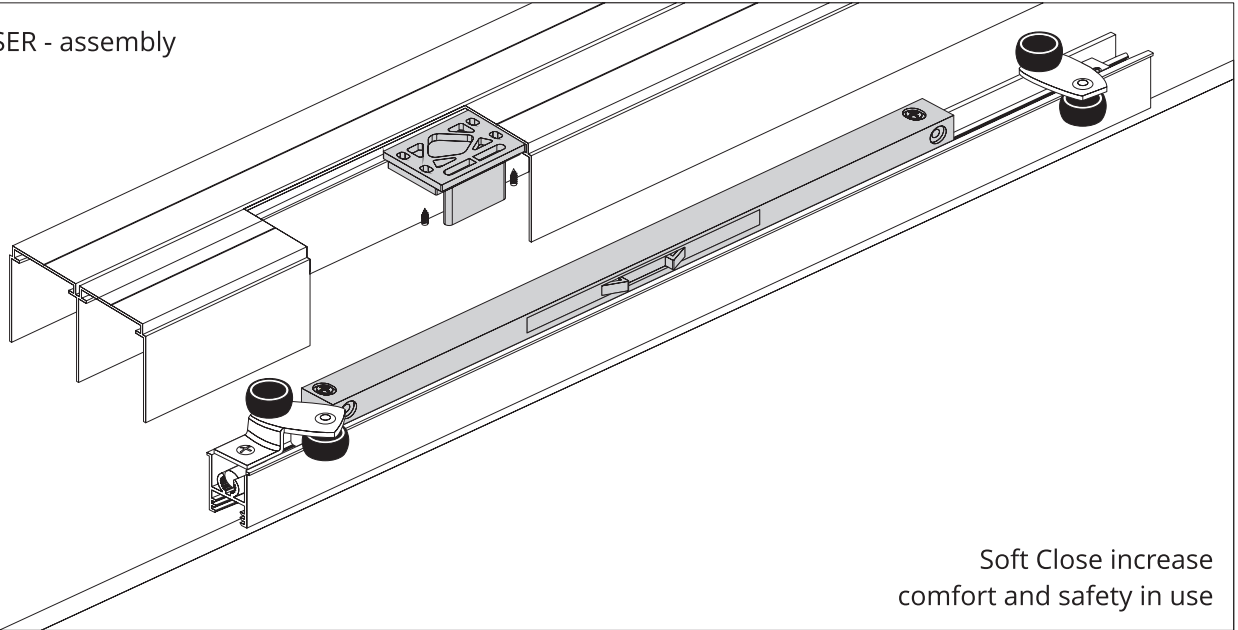

Soft Close increase comfort and safety in use

assembly of the middle soft closer in the door frame

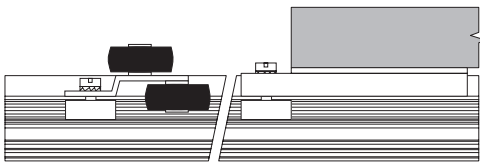

mounting the activator in top rail

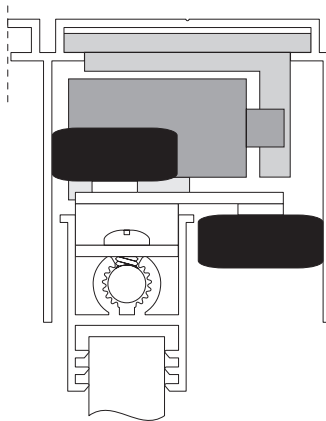

the activator should be inserted into the top rail before installing the door.

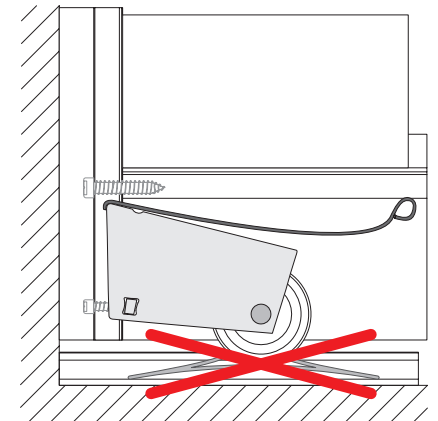

a bottom stopper is not required when using the soft closing system

location of the middle soft closing activator in the top rail

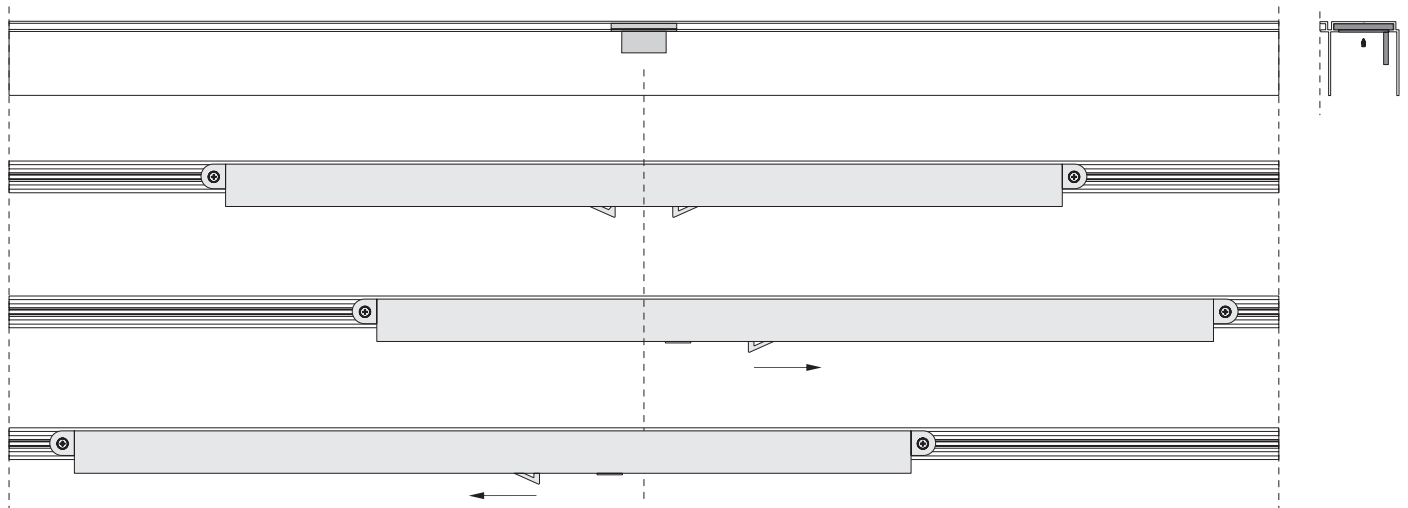



www.czechpol.cz

